



## AC Coupled BESS



**MEGACUBE 373kWh**  
**BATTERY ENERGY STORAGE CABINET ESS**



# MEGACUBE 373kWh

## BATTERY ENERGY STORAGE CABINET

### Description

MEGACUBE 373kWh liquid-cooled energy storage battery cabinets are an integrated high energy density, long lasting, battery energy storage systems utilizing CATL LFP 280Ah cells.

Each battery cabinet includes an IP56 battery rack system, battery management system (BMS), fire suppression system (FSS), HVAC thermal management system and auxiliary distribution system. Outdoor liquid cooled cabinets can be paired together utilizing a high voltage/current battery combiner box to build the ESS size needed.



#### Multiple Applications

Applications of the MEGACUBE include micro-grid, backup power, peak shaving, time of use bill management, frequency regulation, voltage support, renewable integration, and islanding.

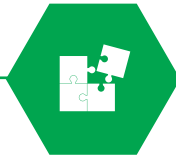

#### Ready to Fit Anywhere

MEGACUBE 373kWh battery energy storage solution is the ideal fit for larger scale commercial & utility applications.

Each cabinet is manufactured to be ready to install by a professional.



#### The future of ESS

Lithium Iron Phosphate (LiFePO4) battery systems connected at high voltage come with 6000 cycle performance guarantee and up to 96% DOD (Depth of Discharge) @ 0.5C 25C





## **Large Scale Li-Ion Battery ESS (LFP) - About**

---

The MEGACUBE 373kWh Battery Energy Storage Solution is an ideal solution for medium to large scale energy storage projects. Utilizing Tier 1 LFP battery cells, each battery cabinet is designed for an install friendly plug-and-play commissioning with easier maintenance capabilities.

Each outdoor cabinet is IP56 constructed in a environmentally controlled liquid cooled cabinet including fire suppression. Multiple 373kWh cabinets can be installed together creating up to 4472kWh energy storage blocks.

Designed for 373kWh's to 100MWh+ systems.

### **BESS Benefits**

---

- More Land Area Savings
- Better Installation Efficiency
- Lower Energy Consumption
- Liquid Cooling with 98% Longer Life
- Adaptable with a Variety of PCS's 600V - 1500V
- Easy to Transport, Install and Maintain
- Almost unlimited expandability

### **Common Applications**

---

- Utility Projects
- Grid Support
- Business' & Factories
- Shopping and Distribution Centers
- Microgrid Island communities
- Renewable Energy Applications

## MEGACUBE 373kWh Battery Energy Storage Cabinet

Item	
DC Data	373kWh
Product Technology	Lithium Iron Phosphate (LFP) LiFePO4
Series - Parallel Mode	1P52S*8S
Nominal Voltage	1331.2 V
Rated Energy	372.7 kWh
Rated Charging Current	0.5C
Rated Discharging	0.5C
Voltage Range	1164.8 ~ 1497.6 VDC
Dimension (W*D*H)	1300 x 1300 x 2280mm
Weight	3500 kg
Cycle Life	≥ 6000 cycles
Ingress Protection	IP56
Cooling Mode Operation	Liquid cooling
Humidity Operational	RH ≤ 85%
Temperature	-20 ~ 50°C
Altitude Limits	< 2000m
Communication	CAN, RS485, Ethernet
Certificates	UL1973, UL9540A, IEC62619, IEC61000

## MEGACUBE 373kWh Battery Energy Storage Cabinet

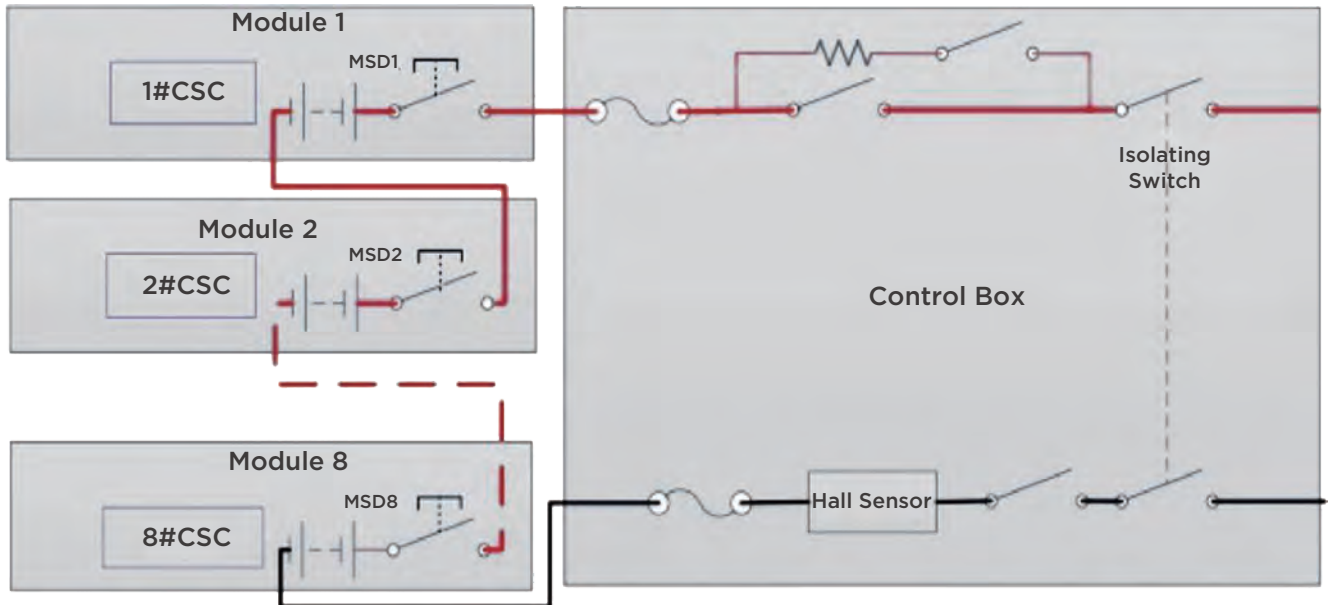

### 373 ESS Includes:

- Battery Racks & Wiring (LFP)
- Outdoor cabinet
- Smoke detector
- Heat detector
- Fire suppression system - aerosol
- HVAC system (liquid cooling unit)
- BMS
- DC switch protection box
- Master control box
- Sub control box
- Combiner & control cabinet (optional)
- Installation Manuals, Certificates, Usage Guide, etc.

## **MEGACUBE 373kWh** Battery Energy Storage Cabinet + Combiner

Item	Data
Number of Racks	9
System output current	1440 A max
Current of rack	160 A max
System voltage C	1500 V max
Output channels	4
Cooling Method	Liquid (ethylene glycol)
Dimensions	800 x 725 x 2100
Weight	~450 kg
Operating temperature	-35~55 °C
IP	1P20 indoor ~ IP56 outdoor



**Battery String Combiner**

Item	Data
DC nominal voltage	166.4 Vdc
DC voltage range	145.6 V ~ 187.2 V
Nominal Capacity	280 Ah
Nominal Energy	46.59 kWh @25°C, 0.5CR
Continuous Max Current	140 A
Cooling Method	Liquid (ethylene glycol)
Dimensions	810mm x 1152mm x 243mm
Weight	~330 kg
Working Temp	Charge: 0°C ~ 55°C Discharge: -20°C ~ 55°C
Cell Arrangement	1P52S



**Battery Module**

## MEGACUBE 373kWh Battery Energy Storage Cabinet



Liquid Cooling Unit

Item	Data
Type	o.5C system
# of chillers/cabinet	1
Cooling capacity per chiller @ 25°C	1.25 kW
Maximum heating power per chiller @ 25°C	2.25 kW
Maximum cooling power per chiller	3 kW
Coolant	BASF Glystantin G30
Max ambient temperature	55 C



# MEGACUBE 373kWh Battery Energy Storage Cabinet

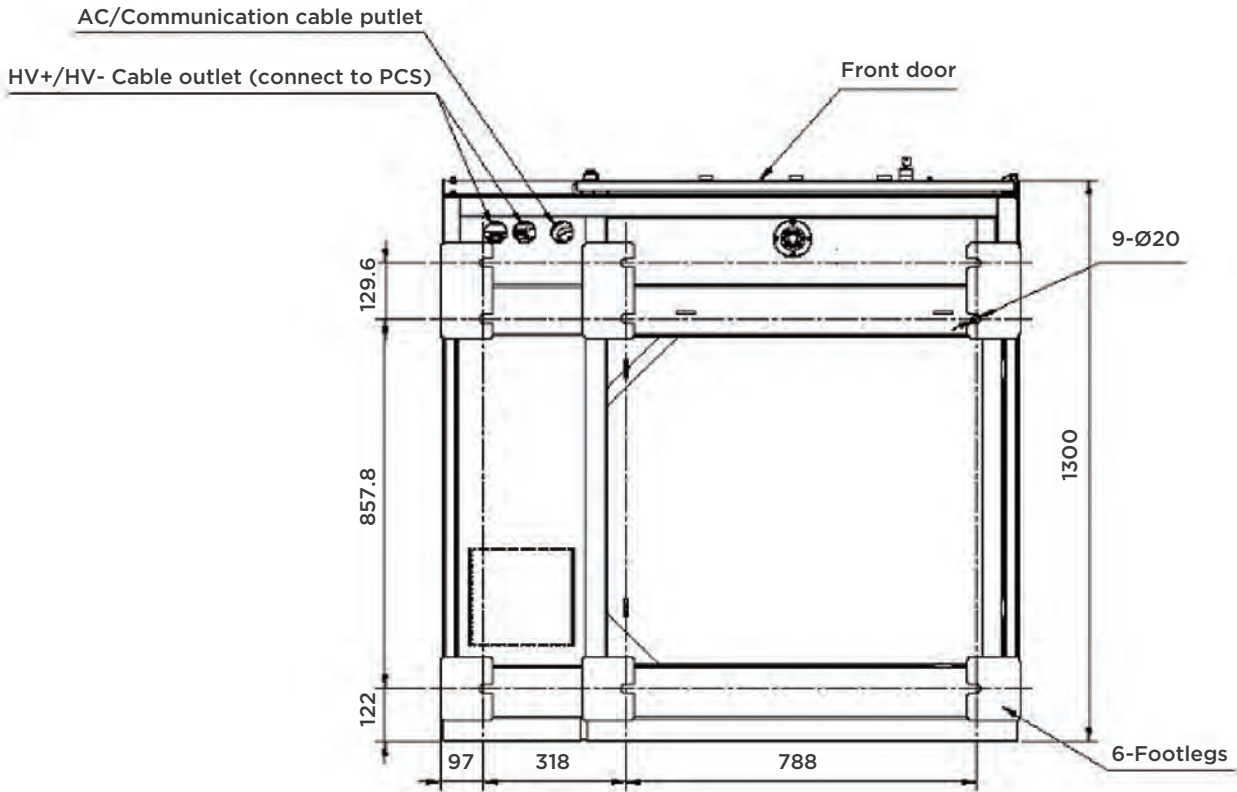

Cabinet Footprint Layout

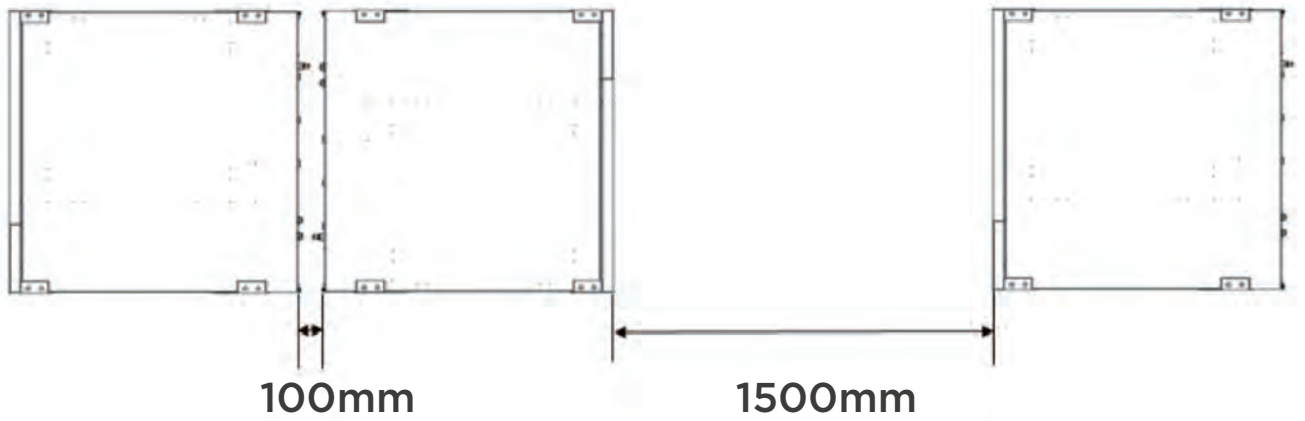

Cabinet Back to Back Layout

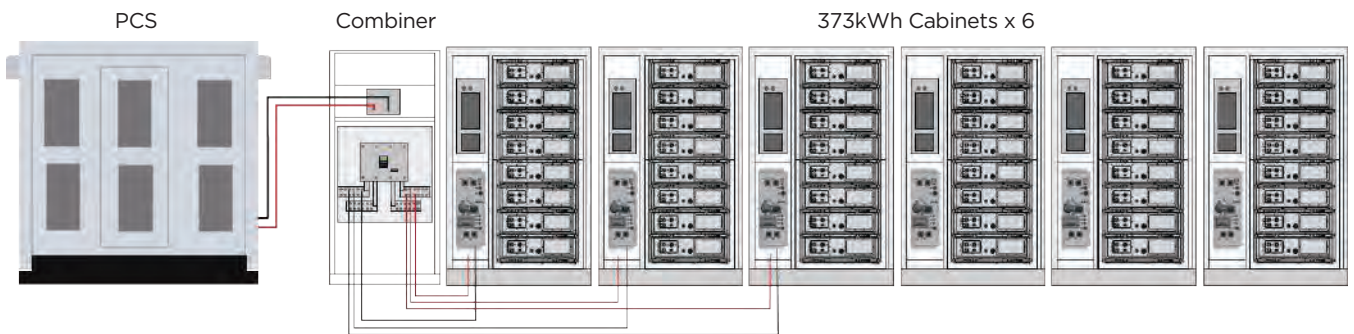

Example System Layout



## BESS System Monitoring

A cloud based energy management system (EMS) can be configured to monitor the BESS and energy storage systems grid access point in real-time.

By monitoring real-time data, and taking safety & stability constraints into consideration, the cloud based EMS can dynamically adjust the energy storage system's charge/discharge strategies based on the project requirements.





**Shinson**<sup>®</sup>  
*Technology Beyond Limits*

Shinson Technology Co.,Ltd

📍 Block#201,No.9 Chuangye Road,  
Changzhou,Jiangsu,PRC

✉ info@shinsontech.com

🌐 www.shinsontech.com

*Product dimensions and physical appearance in this brochure are nominal and are provided for the convenience of our customers. Shinson Group reserves the right to make changes from time to time,without prior notification,which may change the dimensions and physical appearance shown.*